

Original research paper

UDC 681.52:]621.314.58:621.314.63

DOI 10.7251/IJECC2102086P

Implementation of voltage control of buck converter using Beckhoff programmable logic controller

Ognjen Petrić, Srđan Lale and Slobodan Lubura

Faculty of Electrical Engineering, University of East Sarajevo, East Sarajevo, Bosnia and Herzegovina

ognjenpetric@yahoo.com, srdjan.lale@etf.ues.rs.ba, slobodan.lubura@etf.ues.rs.ba

Abstract—The subject of this paper is design, testing and implementation of voltage control of buck power electronics converter using programmable logic controller (PLC) which is based on Beckhoff technology. The proposed control structure is first modelled in the Matlab/Simulink software environment. The built Simulink model is then integrated and transferred to the TwinCAT 3 software which converts personal computer (PC)/laptop into the real-time PLC. This paper proposes an experimental platform consisting of the following components: laptop computer used as the PLC, Beckhoff input/output (I/O) interface, power electronics converter with gate driver module, and electronic modules for measuring and adjusting the signals between the converter and the Beckhoff PLC. In this paper, the control is implemented on the example of the buck converter. However, the proposed modular experimental platform can be used for any type of the converter. Thanks to the integration of the Matlab/Simulink and TwinCAT 3 software environments and the modularity of the platform, the proposed experimental platform is suitable for rapid prototyping of different control structures of power electronics converters, which is especially useful for educational and research purposes. The given experimental results validate excellent performances of the proposed platform.

Keywords - Beckhoff, Matlab/Simulink, TwinCAT 3, buck converter, voltage control, programmable logic controller, rapid control prototyping

I. INTRODUCTION

One of the main trends in the field of power electronics is the demand for topologies and appropriate control techniques that enable the achievement of more efficient energy conversion while reducing the size of the converters and improving their characteristics. The control of the power electronics converters is very important, because it determines their performances, such as dynamical response, robustness to different disturbances, steady-state accuracy, efficiency, etc. It is hard to satisfy all possible different performance criteria, so development of new improved control methods is still very popular scientific topic. To verify existing and new control techniques, it is important to have a modular experimental platform which enables rapid control prototyping and real-time testing. There are various available platforms which are popular in practice for rapid control prototyping, such as: control and data-acquisition boards (dSPACE DS1104 [1], Humusoft MF 634 [2], NI devices with LabVIEW [3], etc.), hardware-in-the-loop (HIL) systems (OPAL-RT [4], Typhoon HIL [5], etc.) and other. These platforms are increasingly used in power electronics, for real-time simulation, HIL simulation and rapid prototyping of different control structures applied to the converters.

This paper proposes the application of programmable logic controller (PLC) for implementation of the control structures of the converters. PLCs are essential parts of industrial automation

control systems. However, their application in power electronics, especially for implementation of different converters' control methods, is relatively rare and limited. The performances of the most PLCs, primarily their speed of digital signal processing, are not good enough to satisfy demands in power electronics applications, in particular applications of pulse-width modulated (PWM) converters. Control algorithms of the PWM converters often require fast signal processing and complicated calculations, which is hard to accomplish with the conventional PLCs. Lately, personal computer (PC) – based PLCs, such as Beckhoff Automation PLCs [6], [7], are increasingly popular in different automation control systems. Unlike conventional PLCs, Beckhoff PC-based PLCs are implemented on PC or laptop by using TwinCAT software environment which converts PC/laptop into the real-time controller, with the possibility of multiple PLCs on a single computer. This kind and concept of PLC offers numerous excellent performances and benefits, such as compactness, user-friendly operation, high speed of signal processing, modularity, easier human-machine interaction, lower cost, etc. These features are mainly ensured by the fact that this kind of PLC is implemented on the computer/laptop and it uses computer's processor and resources, which is a great advantage over standard PLCs. Also, thanks to the integration of the TwinCAT and Matlab/Simulink software environments, Beckhoff PLCs can be programmed using Simulink, which is very important for rapid control prototyping.

Considering all mentioned benefits of the Beckhoff PC-based PLCs, this paper proposes the application of the Beckhoff PLC for implementation of the converters' control structures, which is not typical application of the PLCs. For this purpose, a modular cost-effective experimental platform is proposed, which can be used for rapid prototyping and testing of various converters' control methods. As an example, voltage control of the DC-DC buck converter is implemented.

This paper is composed of several sections. The second section briefly describes the working principles and mathematical modelling of the buck converter. Voltage control of the buck converter is described in section III. The Beckhoff PLC with TwinCAT 3 and Matlab/Simulink software environments is presented in section IV. Practical implementation and experimental results are given in sections V and VI, respectively. Section VII gives the concluding remarks and future work directions.

II. BUCK CONVERTER

Fig. 1 shows the basic electrical diagram of the DC-DC buck converter. Depending on the PWM switching signal u , there are two operating modes of the buck converter. When $u=1$, the power switch T is turned on, the diode D is turned off and the inductor L stores energy. The corresponding equations which describe this state for $u=1$ are following:

$$v_L(t) = L \frac{di_L(t)}{dt} = v_g(t) - v_o(t) \quad (1)$$

$$i_C(t) = C \frac{dv_o(t)}{dt} = i_L(t) - \frac{v_o(t)}{R}, \quad (2)$$

where $v_L(t)$, $v_g(t)$, $v_o(t)$, $i_L(t)$ and $i_C(t)$ are inductor voltage, input voltage, output (load) voltage, inductor and capacitor current, respectively, of the buck converter. Parameters L , C and R represent inductance, capacitance and resistance of the filter inductor, output filter capacitor and load, respectively.

When $u=0$, the power switch T is turned off, the diode D is turned on and the inductor L releases the previously stored energy. This state is described with following equations:

$$v_L(t) = L \frac{di_L(t)}{dt} = -v_o(t) \quad (3)$$

$$i_C(t) = C \frac{dv_o(t)}{dt} = i_L(t) - \frac{v_o(t)}{R}. \quad (4)$$

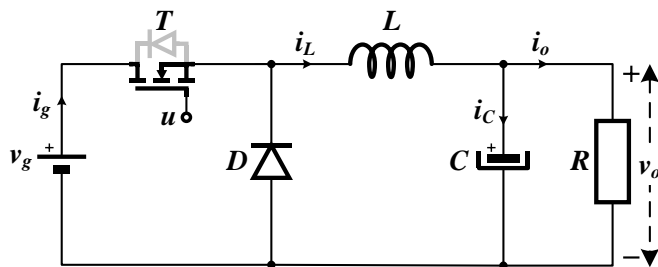

Figure 1. DC-DC buck converter.

Applying volt-second balance on the inductor, the value of the output voltage in steady state V_o is obtained as:

$$V_o = DV_g, \quad (5)$$

where V_g is the value of the input voltage in steady state and D is the duty cycle (ratio) of the PWM switching signal u . The duty cycle D has values from 0 to 1, which means that the output voltage of the buck converter is always lower than the input voltage, according to (5).

Also, from the DC analysis of the buck converter from Fig. 1, it is obtained that the output load current I_o in steady state is equal to the average value of the inductor current I_L :

$$I_o = \frac{V_o}{R} = I_L. \quad (6)$$

Equations (1) and (3) can be combined into single equation which depends on the switching signal u :

$$v_L(t) = L \frac{di_L(t)}{dt} = u(t)v_g(t) - v_o(t). \quad (7)$$

For derivation of the converter's transfer functions, which are used for dynamical analysis and control design, it is necessary to apply Laplace transform on the obtained time-domain state equations. However, it is not possible to apply Laplace transform on the nonlinear equation such as (7). Therefore, its linearization must be performed. To derive linearized model of any converter, a small-signal analysis is usually performed [8]. After small-signal (small-ripple) approximation of the equations (1)-(4), the linearized small-signal equations of the buck converter working in continuous-conduction mode are obtained [8]:

$$L \frac{d\hat{i}_L(t)}{dt} = D\hat{v}_g(t) + \hat{d}(t)V_g - \hat{v}_o(t) \quad (8)$$

$$C \frac{d\hat{v}_o(t)}{dt} = \hat{i}_L(t) - \frac{\hat{v}_o(t)}{R}, \quad (9)$$

where $\hat{i}_L(t)$, $\hat{v}_g(t)$, $\hat{v}_o(t)$ and $\hat{d}(t)$ are small AC perturbations of the inductor current, input voltage, output voltage and duty cycle, respectively.

For design of the output voltage regulator, it is necessary to derive the transfer function from the duty cycle $\hat{d}(t)$ to the output voltage $\hat{v}_o(t)$. This transfer function is obtained after Laplace transform of (8) and (9):

$$G_{vd}(s) = \left. \frac{\hat{v}_o(s)}{\hat{d}(s)} \right|_{\hat{v}_g(s)=0} = \frac{V_g}{1 + s \frac{L}{R} + s^2 LC}. \quad (10)$$

Now, procedure for design of the output voltage regulator can be implemented.

III. VOLTAGE CONTROL OF BUCK CONVERTER

Fig. 2 shows the schematic diagram of the voltage control applied to the general converter's type. The basic task of the voltage control is the regulation of the converter's output (load) voltage v_o , in accordance with the reference voltage v_{ref} . To achieve this task, a control structure with the voltage regulator $C(s)$ is used (Fig. 2a)).

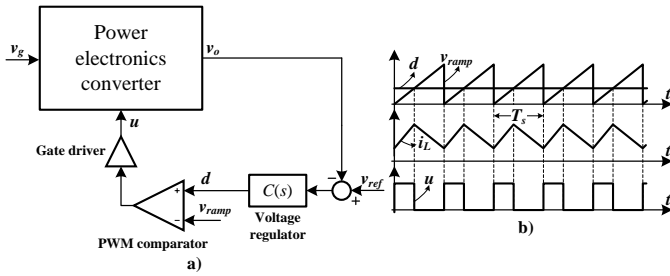

Figure 2. Voltage control of the power electronics converters: a) Block-diagram, b) Characteristic voltage control signals.

The difference between the reference voltage v_{ref} and the measured output voltage v_o (the error signal) is fed to the input of the regulator $C(s)$. The output of the voltage regulator $C(s)$ is the duty cycle d , which is used as the input of the PWM block (PWM comparator from Fig. 2a)). The duty cycle d is compared with the ramp carrier signal v_{ramp} , which has a constant switching frequency $f_s=1/T_s$, where T_s is the switching period of the PWM signal u . As a result, at the output of the PWM comparator, control pulses u are obtained (Fig. 2b)), with the switching frequency f_s and the corresponding duty cycle d , which ensures the equality of the output and reference voltage in the steady state. In addition to the sawtooth (Fig. 2b)), other waveforms of the carrier signal v_{ramp} may be used, such as inverted sawtooth, triangular, etc. In the conventional voltage control variant, the carrier signal v_{ramp} has a constant amplitude. However, a variable adaptive amplitude can also be applied, to improve the response of the converter to the changes in the input voltage.

Fig. 2 shows a general block diagram of the voltage control of any type of converter. For the buck converter, which is considered in this paper, it is necessary to design the voltage regulator $C(s)$ with the appropriate parameters, to achieve the desired control performances. For that purpose, the control-to-output transfer function $G_{vd}(s)$ from (10) is used in the design procedure. Linear regulators, such as proportional, integral and derivative regulators, or their combinations, are most often used in practice. In this paper, a simple integral (I) regulator is proposed as the output voltage regulator $C(s)$:

$$C(s) = \frac{k_i}{s}, \quad (11)$$

where k_i is the integral gain. This simple regulator ensures satisfactory control performances, especially in steady state. For better transient response during different disturbances, especially on the load side, other types of the regulator should be used.

By using transfer functions (10) and (11), a loop gain $L(s)$ of the system can be obtained as:

$$L(s) = C(s) \cdot G_{vd}(s) = \frac{k_i V_g}{s \left(1 + s \frac{L}{R} + s^2 LC \right)}. \quad (12)$$

A characteristic equation is equal to:

$$\lambda(s) = 1 + L(s) = LCs^3 + \frac{L}{R}s^2 + s + k_i V_g = 0. \quad (13)$$

Applying a simple pole-placement technique to the characteristic equation (13), the value of the integral gain k_i can

be easily obtained. For example, if a desired characteristic polynomial $\lambda_d(s)$ is chosen as:

$$\lambda_d(s) = LC(s^2 + 2\zeta w_n s + w_n^2)(s + \sigma), \quad (14)$$

where ζ and w_n are damping factor and natural frequency, respectively, by equalizing (13) and (14) the gain k_i can be expressed as the function of parameter σ :

$$k_i = \frac{LCw_n^2\sigma}{V_g}. \quad (15)$$

By changing σ , which determines the response speed, different values of the gain k_i can be set.

In practice, there are different ways, i.e., electronic platforms for the implementation of the control systems. In this paper, the application of the Beckhoff PLC for the implementation of the described voltage control of the buck converter is proposed.

IV. BECKHOFF PROGRAMMABLE LOGIC CONTROLLER WITH TWINCAT SOFTWARE ENVIRONMENT

Beckhoff Automation GmbH [6] manufactures the equipment for industrial automation in the form of individual components and system solutions. Since its inception, the Beckhoff has focused on the control equipment compatible with personal computers, industrial computers, embedded computers, input/output (I/O) modules, as well as on the production of servo motors and the development of automation software [9].

The Beckhoff products are being used in different industry areas, such as automation control systems in the gas, oil and chemical industries, power engineering, transport, automation of various types of plants and many other. Main categories of Beckhoff products are industrial computers, I/O terminals, servo motors, and the TwinCAT software environment [6], [9]. In this paper, the TwinCAT 3 software was used for programming of the Beckhoff PLC, and it will be described in more detail below.

The Beckhoff TwinCAT software system converts almost all compatible computers into the real-time controllers with the possibility of multiple PLCs on a single computer, with a complete programming environment and workstation. This is one of the main advantages of the TwinCAT software environment, and this advantage was used for the realization of the practical part of this paper, which means that a laptop was used instead of the conventional PLC. TwinCAT software environment combines the capabilities of the real-time controller with Microsoft Windows operating system. TwinCAT consists of run time systems, that execute main program in real time, and development environments for programming, diagnostics, and configuration. All Windows programs, such as visualization or Office programs, can access TwinCAT data through the Microsoft interface, or can execute commands. TwinCAT PLC is programmed in accordance with the IEC 61131-3 standard [10]. TwinCAT supports all IEC 61131-3 programming languages. PLC programs created using TwinCAT can run on multiple target platforms. In addition to industrial computers and embedded computers, the PLC project can be loaded into BC and BX serial fieldbus controllers from Beckhoff [7].

To reduce design time, a modular control and management software is becoming a new trend in which individual functions or assemblies are considered as modules. The modules are

independent and arranged in a hierarchy in such a way that the lowest modules are the simplest and basic elements for reuse. Individual modules can be expanded, customized and reused independently of each other. This is a type of programming that uses TwinCAT 3 and that is why TwinCAT 3 is called eXtended Automation (XA) [7].

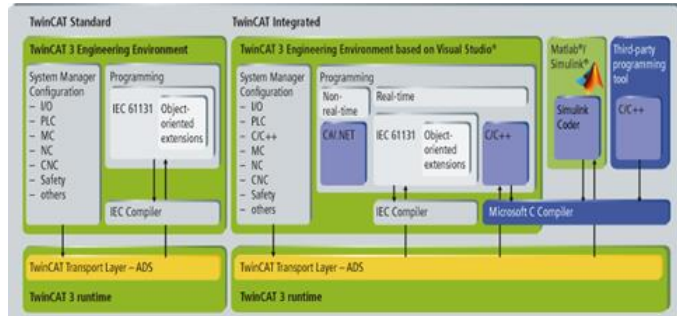

Figure 3. TwinCAT 3 eXtended Automation Technology (XAT) [7].

Extended Automation Technology (Fig. 3) is a combination of the latest software tools and automation technology. Its main approach is to simplify software engineering, so that instead of developing stand-alone tools, it can be integrated into common and existing software development environments, such as Microsoft Visual Studio.

TwinCAT allows users to import models created in Matlab/Simulink environment for any type of the specific control system and use them as if they were originally created in the TwinCAT environment. This type of communication provided by the TwinCAT Transport Layer (Fig. 3) gives users the opportunity to fully develop and control different systems using only TwinCAT and system modules created in Simulink [6], [7].

For proper communication between TwinCAT and Matlab/Simulink, it is necessary to use two TwinCAT functions called TE1400 and TE1410 (Fig. 4, Fig. 5). They can be downloaded from the Beckhoff site and run in the Matlab environment [6], [7], [11], [12].

Simulink Coder contains a code generator that generates the appropriate C/C++ code from the Simulink model, which is necessary for the TwinCAT Target for the Matlab/Simulink. If the code generator is configured correctly, a TwinCAT object model (TcCOM) is created. This type of model can be imported into the TwinCAT 3 development environment (TC3 XAE) and reconfigured there if needed. When the TC3 runtime is started, the created model is executed in real time and integrated into the real process control and management system [7], [12].

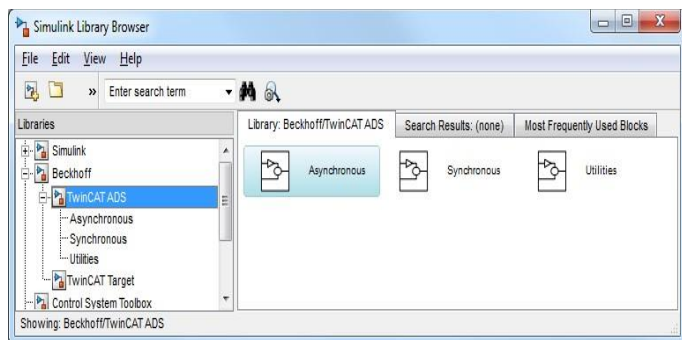

Figure 4. TE1410 Matlab/Simulink library [7], [11].

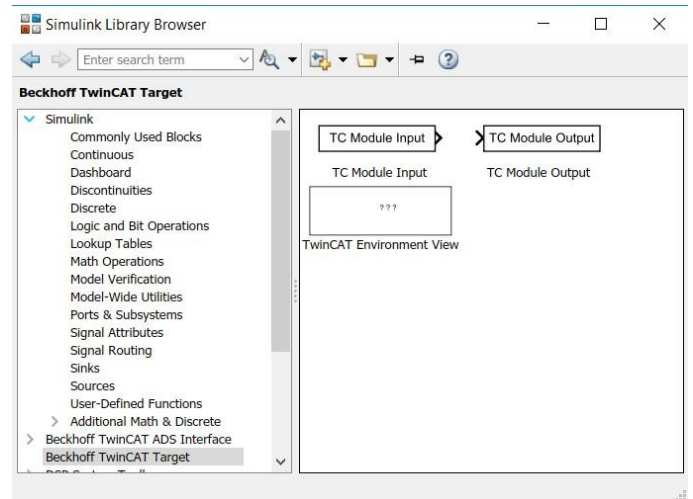

Figure 5. TE1410 TwinCAT library [7], [12].

V. PRACTICAL IMPLEMENTATION

The complete proposed system consists of several functional units which are shown in the form of block-diagram on Fig. 6. The complete control structure, i.e., voltage control loop, is implemented in Matlab/Simulink, and then integrated into the TwinCAT software environment in which it is executed. Thanks to the software capabilities of TwinCAT, the laptop is actually a PLC which is connected to the I/O terminals via EK1100 EtherCAT coupler (Fig. 7) [6]. In this case, the analog input terminal EL3164 (Fig. 8) and the output PWM terminal EL2502 (Fig. 9) [6] were used.

The buck converter (Fig. 10) is implemented as SPM-HB SiC half bridge power module [13], which is connected to the GDC-2A2S1 gate driver module [14]. Important feature of the GDC-2A2S1 gate driver is galvanic isolation between its inputs and outputs. The output PWM terminal EL2502 provides PWM control signals for the gate driver. It is important to note that the input PWM signals of the gate driver GDC-2A2S1 must have TTL 5 V level. However, the PWM output terminal EL2502 of the Beckhoff PLC produces PWM signals with 24 V level. Therefore, it is necessary to make a simple adaptive electronic circuit to scale the PWM signal voltage from 24 V to 5 V.

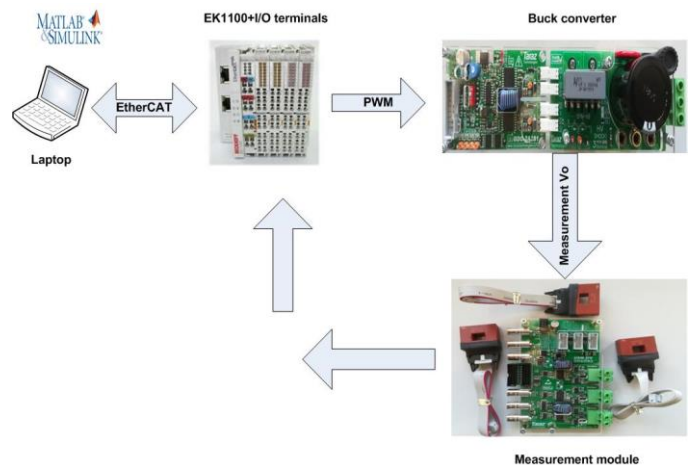

Figure 6. Block-diagram of the proposed experimental platform.

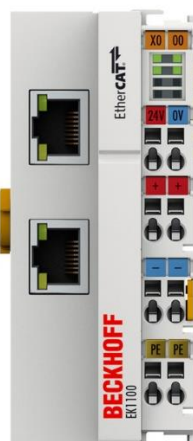

Figure 7. EK1100 EtherCAT coupler [6].

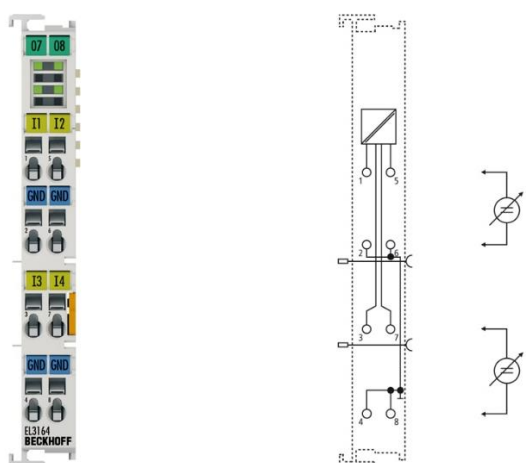

Figure 8. EL3164 analog input terminal [6].

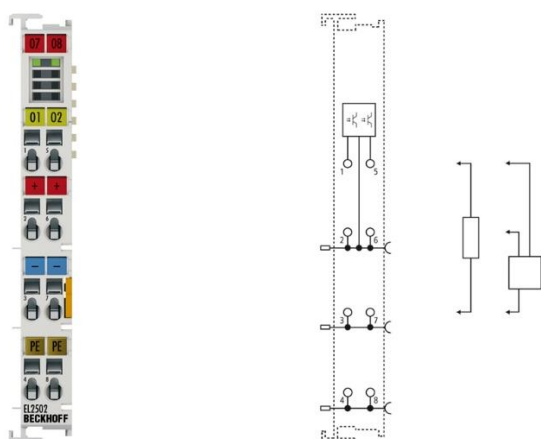

Figure 9. EL2502 output PWM terminal [6].



Figure 10. Synchronous buck converter (right) with gate driver module (left).

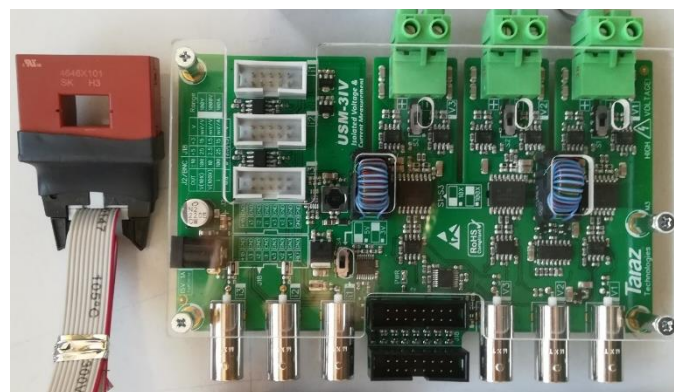

Figure 11. USM-3IV measurement electronic module.

The measurement of the output voltage and inductor current of the buck converter is realized with the measurement electronic module USM-3IV [15], shown on Fig. 11. This module has three channels for voltage and three channels for current measurement, with galvanic isolation between input and output. The module is compatible with VAC 100 A current sensor [16]. Also, the USM-3IV module provides the scaling of the measured voltage and current to the ± 10 V range, which is necessary for the analog input terminal EL3164.

It is necessary to provide power supplies for the buck converter (30 V DC), gate driver module (15 V DC), measurement module (15 V DC) and EtherCAT coupler with the corresponding I/O modules (24 V DC).

The measured scaled output voltage of the buck converter is fed to the analog input terminal of the Beckhoff PLC, and the closed feedback loop is achieved. The voltage regulator is implemented in real time in TwinCAT 3 environment on the laptop. The PWM control signal, with corresponding calculated value of the duty cycle, is exported from the PWM output terminal and fed to the adaptive electronic circuit and then to the input of the gate driver.

The experimental setup of the described platform, which is realized in the ELEMEND laboratory of the Faculty of Electrical Engineering in East Sarajevo, is given in Fig. 12.



Figure 12. The experimental setup of the proposed system.

VI. EXPERIMENTAL RESULTS

In the Matlab/Simulink program, a scheme (model) of the voltage regulator, which is used to control the operation of the buck converter, was first created.

The basic element of the implemented control scheme is the I voltage regulator, which is described in section III of this paper.

After creating the control model in the Matlab/Simulink program, it is integrated into the TwinCAT 3 software environment, so that its input and output signals can be connected to the real Beckhoff I/O terminals. The control TwinCAT 3 model is shown in Fig. 13.

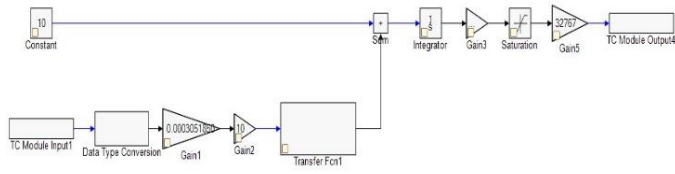

Figure 13. Control model in the TwinCAT 3 software environment.

Table I shows the values of all parameters used in the experiments.

TABLE I. LIST OF PARAMETER VALUES.

Parameter	Description	Value
T_{sample} [s]	Period of discretization	10^{-3}
f_s [kHz]	PWM switching frequency	20
k_i	Gain of the I voltage regulator	0.357
V_g [V]	Input voltage of the buck converter	30
L [μ H]	Coil inductance of the buck converter	220
C [μ F]	Output capacitance of the buck converter	1000
R [Ω]	Load resistance	4

To confirm the correct operation of the proposed experimental platform, several experimental tests were performed. The corresponding experimental results, i.e., the experimental waveforms of the output voltage v_o and the inductor current i_L of the buck converter, are given below. The shown waveforms were recorded with the oscilloscope SIGLENT SDS1202X-E.

The experimental results were obtained for different values of the reference voltage: $v_{ref} = 10$ V (Fig. 14, Fig. 18), $v_{ref} = 15$ V (Fig. 15, Fig. 19), $v_{ref} = 20$ V (Fig. 16, Fig. 20), and $v_{ref} = 24$ V (Fig. 17, Fig. 21).

It is obvious from the given results that the implemented voltage control ensures excellent steady-state accuracy for all considered values of the reference voltage. Also, the duty cycle

of the switching pulses has expected values, which can be seen from the inductor current waveforms.

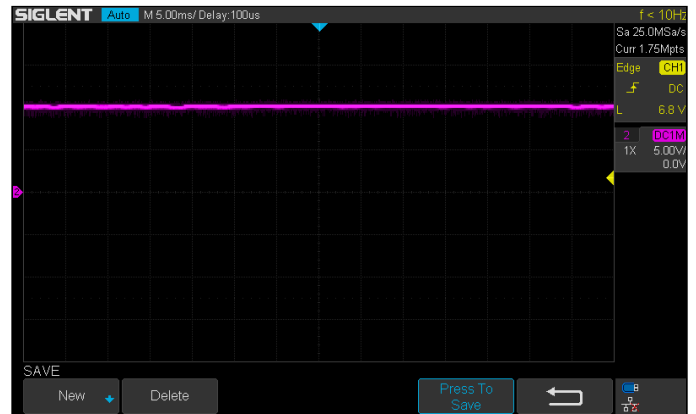

Figure 14. Output voltage of the buck converter in steady state, for the reference voltage $v_{ref} = 10$ V.

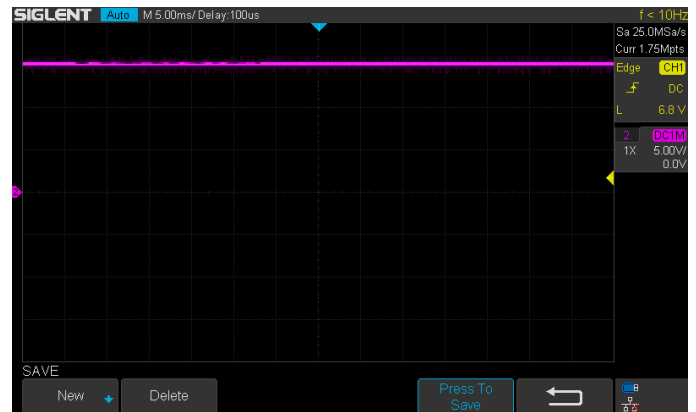

Figure 15. Output voltage of the buck converter in steady state, for the reference voltage $v_{ref} = 15$ V.

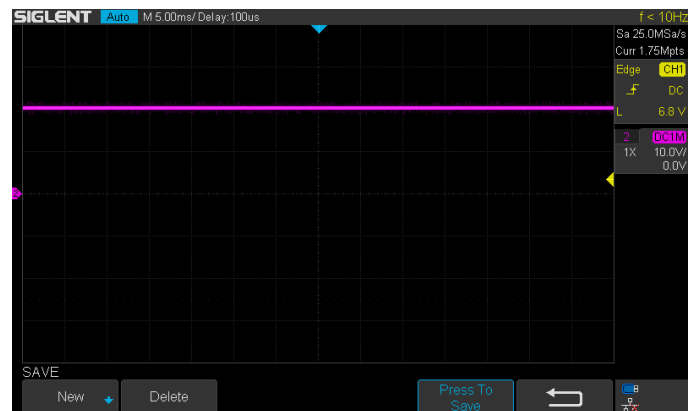

Figure 16. Output voltage of the buck converter in steady state, for the reference voltage $v_{ref} = 20$ V.

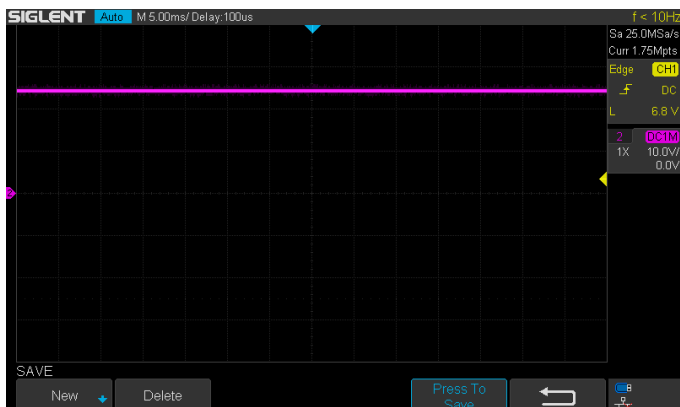

Figure 17. Output voltage of the buck converter in steady state, for the reference voltage $v_{ref} = 24$ V.

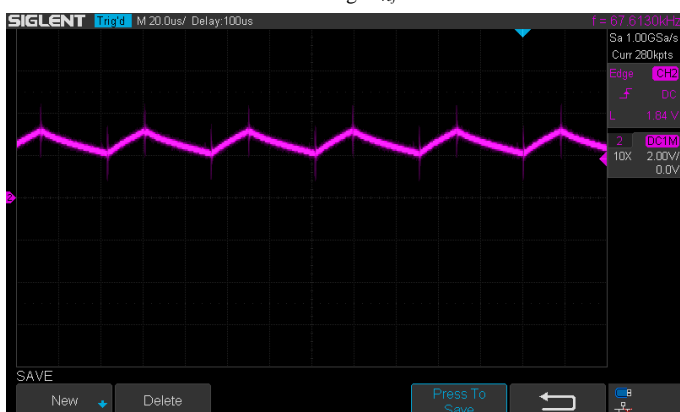

Figure 18. Inductor current of the buck converter in steady state, for the reference voltage $v_{ref} = 10$ V.

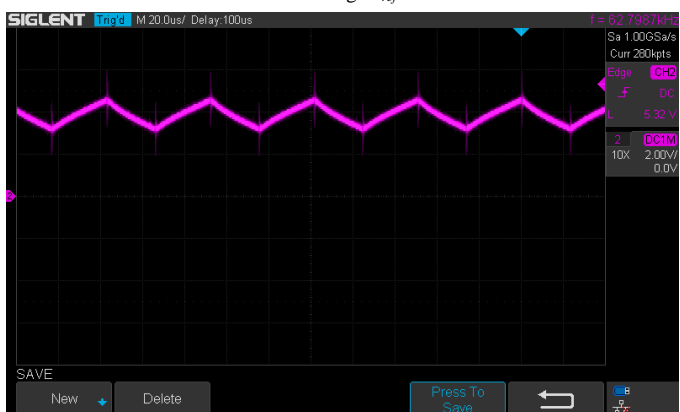

Figure 19. Inductor current of the buck converter in steady state, for the reference voltage $v_{ref} = 15$ V.

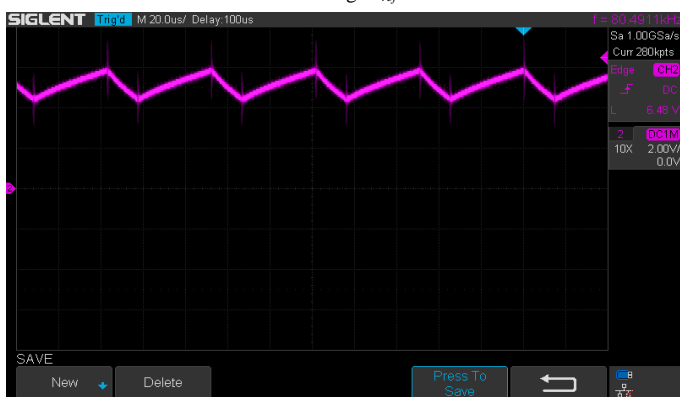

Figure 20. Inductor current of the buck converter in steady state, for the reference voltage $v_{ref} = 20$ V.

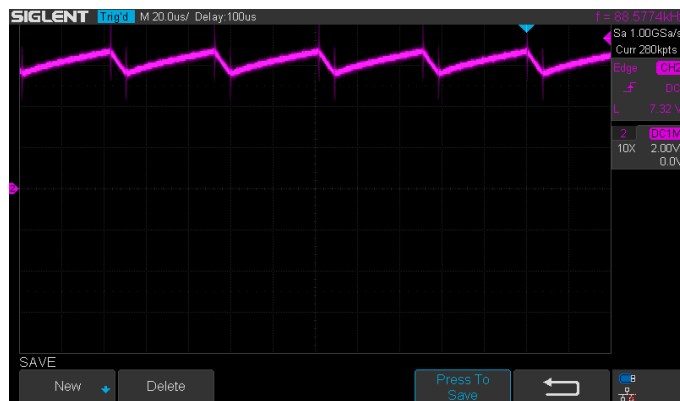

Figure 21. Inductor current of the buck converter in steady state, for the reference voltage $v_{ref} = 24$ V.

To verify the dynamical response of the buck converter, step changes of the reference voltage from 10 V to 20 V, and vice versa, were performed. The experimental waveforms of the output voltage for these cases are given on Fig. 22 and Fig. 23, respectively. It can be concluded that the buck converter with the implemented voltage control has excellent transient response. The obtained output voltage has expected waveforms in the transient regimes, according to the control design procedure, which is explained in section III.

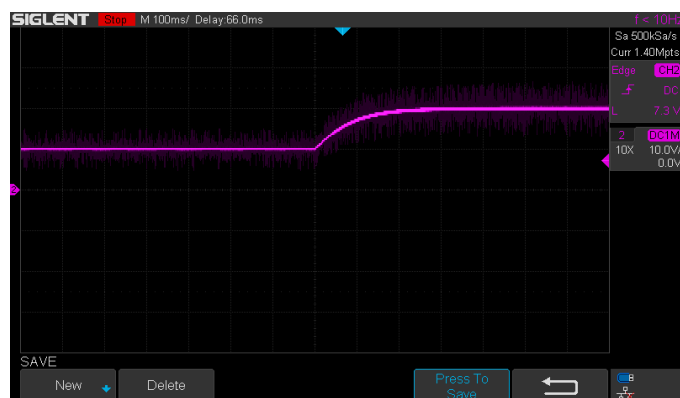

Figure 22. Output voltage of the buck converter during the step transition of the reference voltage from 10 V to 20 V.

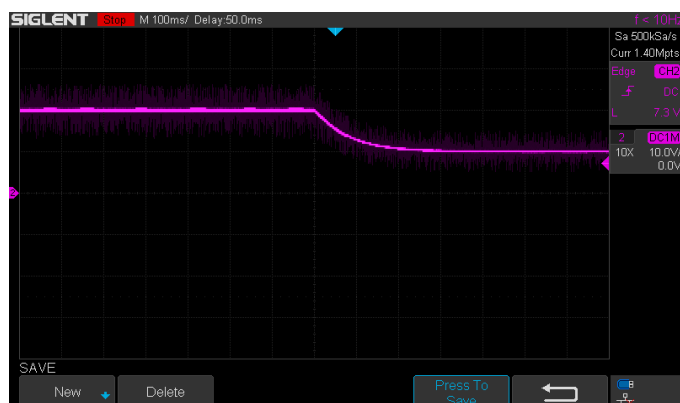

Figure 23. Output voltage of the buck converter during the step transition of the reference voltage from 20 V to 10 V.

VII. CONCLUSION

This paper proposes the cost-effective, modular, user-friendly experimental platform, which can be used for rapid prototyping and testing of control structures for power

electronics converters. The proposed platform is based on the application of the Beckhoff PLC, which is implemented on PC/laptop by using TwinCAT software environment.

The advantage of the proposed solution compared to the others is reflected in the simplicity and speed of programming. The integration of the Matlab/Simulink and TwinCAT 3 software packages enables full graphical programming of the Beckhoff PLCs using models developed in the Matlab/Simulink. This means that PLC programming does not require knowledge of any specific PLC programming language, but only modelling knowledge in Simulink. It is important to note that after integration of the developed control model from the Matlab/Simulink into the TwinCAT 3 environment, all further adjustments and parameter changes can be performed directly from the TwinCAT 3. Also, the created models are graphically displayed in the same way in both environments. Even during commissioning, where user does not have the Matlab/Simulink environment available, there is still a graphical representation of the developed system which can be used for signal monitoring, parameter changes, etc. The TwinCAT 3 is very well connected to the Matlab/Simulink and supports all the tools from the Simulink Coder.

The Beckhoff PLC uses computer's processor and all its resources, which results in very high speed of signal processing.

In this paper, the proposed experimental platform is used for implementation of the voltage control of the DC-DC buck converter. The given experimental results prove the validity and excellent performances of the platform. With minor configuration changes in the converter topology and control structure, this platform can be easily adjusted to other types of the converters. Thanks to the possibility of graphical programming from Simulink, more complex control algorithms can be implemented. Also, it is possible to upgrade the proposed platform with additional I/O terminals and power modules, which enables the rapid control prototyping of more complex power electronics systems.

Considering all these benefits and properties, the proposed platform could be a very useful tool for education, in power electronics courses.

It should be noted that this is a completely new chapter in industrial automation, where PLCs are traditionally used to control industrial plants. It can be expected that this kind of PC-based PLC will have important practical application in the areas of power electronics, especially in rapid development and experimental testing of new various converter's control techniques.

REFERENCES

- [1] dSPACE, "DS1104 R&D Controller Board, Cost-effective system for controller development," data-sheet, January 2020.
- [2] Humusoft, "MF 634 Multifunction I/O card," user's manual, 2014.
- [3] NI, "Multifunction input and output devices," product flyer.
- [4] OPAL-RT, "OP4510 Simulator, RT-LAB/RCP/HIL System," data-sheet.
- [5] Typhoon HIL, "HIL606 Brochure," product information.
- [6] <https://beckhoff.com>, November 2021.
- [7] <https://infosys.beckhoff.com/>, November 2021.
- [8] R. W. Erickson, D. Maksimović, "Fundamentals of power electronics," 2nd ed., Boston, MA: Kluwer, 2001.
- [9] Proskuriakov Mikhail, „Control of a hydraulic servo system using Beckhoff real-time data acquisition computer based on Matlab/Simulink platform," Lappeenranta University of Technology, master thesis, 2018.
- [10] IEC 61131-3 International Standard, "Programmable controllers – Part 3: Programming languages," Edition 3.0, 2013-02.
- [11] Beckhoff, "TC3 Interface for Matlab®/Simulink®," manual, 2017.
- [12] Beckhoff, "TC3 Target for Matlab®/Simulink®," manual, 2020.
- [13] Taraz Technologies, "Half bridge power module SPM-HB," data-sheet, 2015.
- [14] Taraz Technologies, "High CMR Isolated 2SW 2A smart gate drive module for SiC FETs GDC-2A2S1," data-sheet, 2019.
- [15] Taraz Technologies, "Isolated voltage & current sensing module USM-3IV," data-sheet, 2015.
- [16] VAC, "100 A current sensor," data-sheet, 2019.



Ognjen Petrić was born in Sarajevo in 1992. He received B.Sc. degree at Faculty of Electrical Engineering, University of East Sarajevo, in 2018. His research interests include programmable logic controllers, industrial automation, mechatronics and power electronics.



Slobodan Lubura was born in Sarajevo in 1969. He received B.Sc., M.Sc. and PhD degrees at Faculty of Electrical Engineering, University of East Sarajevo, in 2000, 2006 and 2009, respectively. His research interests include mechatronics, power electronics, control of power electronics converters and renewable power sources.



Srđan Lale was born in Sarajevo in 1987. He received B.Sc. and M.Sc. degrees at Faculty of Electrical Engineering, University of East Sarajevo, in 2010 and 2013, respectively, and PhD degree at Faculty of Electronic Engineering, University of Niš, in 2018. His research interests include power electronics, control of power electronics converters and renewable power sources.